

AVANT[®]

99-95200403 - ISSUE 8

ENGLISH

EARTH DRILL OPERATORS MANUAL



www.avantteco.com

INDEX



| | |
|--------------------------------------------------------------------|----|
| FOREWORD | 4 |
| Enquiries | 4 |
| The Machinery Directive (European Community only) | 4 |
| Declaration Of Conformity | 4 |
| REGISTRATION | 6 |
| INTRODUCTION | 9 |
| SAFETY NOTES | 10 |
| Protect Yourself | 10 |
| You May Need | 10 |
| Know Your Equipment | 10 |
| Danger, Warning And Caution | 10 |
| Protective And Safety Devices | 11 |
| Check The Equipment | 11 |
| Hazard Classification (Only applicable to ANSI Safet Labels) | 11 |
| Safety Precautions | 12 |
| IDENTIFICATION | 13 |
| Typical Setup | 13 |
| MOUNTING - HITCH FITTING | 14 |
| HYDRAULIC CONNECTIONS | 16 |
| Connecting the Multiconnector System | 16 |
| Conventional Quick Couplings | 17 |
| Releasing Residual Hydraulic Pressure | 17 |
| Hoses Specifications | 17 |
| RUNNING-IN | 18 |
| FITTING THE AUGER | 19 |
| PREPARATION | 20 |
| WORKING PROCEDURE | 21 |
| DRILLING WITH FIXED EXTENSIONS | 22 |
| REMOVING A FIXED EXTENSION | 23 |

| | |
|--------------------------------------------|----|
| STUMP PLANER | 24 |
| Fitting The Planer | 24 |
| Engaging Blades | 25 |
| Cutting Sequence..... | 25 |
| TRANSPORTATION | 26 |
| Transportation On Public Highways..... | 26 |
| Transportation Within The Job Site | 26 |
| MAINTENANCE & LUBRICATION | 27 |
| Service Intervals | 28 |
| Recommended Oil Change Intervals | 29 |
| Recommended Lubricants | 29 |
| Oil Change Procedure | 30 |
| Component Wear..... | 31 |
| Auger Tooth Replacement | 32 |
| Shock Lock Teeth..... | 32 |
| Stump Planer Blade Removal | 33 |
| Sharpening Blades | 33 |
| Blade Life | 33 |
| Pilot Replacement..... | 33 |
| TROUBLESHOOTING | 34 |
| WARRANTY STATEMENT | 36 |

FOREWORD

Enquiries

Please state the model type and serial number when making enquiries or orders and all written correspondence. The serial number is recorded on a plate located on the top of the drive unit.

| | | | | | |
|----------------------|-----------------------------------------------------------------------------------|----------------------|----------------------|-----------------|-----------------------------------------------------------------------------------|
| 99-5057 |  | | AUGERTORQUE® | Distributed by: |  |
| Model: | Serial No: | Weight: | | | |
| <input type="text"/> | <input type="text"/> | <input type="text"/> | | | |
| Flow Range: | From | To | CE | | |
| Pressure Range: | From | To | | | |
| Max. Back Pressure: | <input type="text"/> | Date of Manufacture | <input type="text"/> | | |

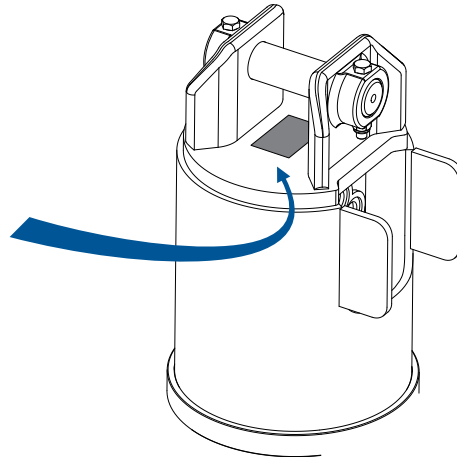

The Machinery Directive (European Community only)

The Machinery Directive 2006/42/EC (formerly 98/37/EEC) provides the harmonisation of the essential health and safety requirements for machinery, through a combination of mandatory health and safety requirements and voluntary harmonised standards. Such directives apply only to products that are intended to be placed on or put into service in the market for the first time. The manufacturer or the authorised representative must draw up a 'Declaration of Conformity'.

Declaration Of Conformity

Where Earth Drill Units are supplied in conjunction with Auger Torque Europe Ltd manufactured mounting frames and Augers to form an Earth Drill Assembly, Auger Torque Europe Ltd have control over the suitability of the parts supplied. To show this and meet with the lawful requirements of the Machinery Directive a Declaration of Conformity is issued and a CE mark is applied to the assembly.

(copy example follows)



AUGER TORQUE

Manufactured By
Auger Torque Europe Limited

EU Declaration of Conformity

The responsible person:

| | |
|--------------|----------------------------------------------------|
| Name | |
| Position | |
| Company Name | <i>Auger Torque Europe Ltd.</i> |
| Address | <i>Hazelton, Cheltenham, GL54 4DX, England</i> |
| Telephone | <i>++44 (0) 1451 861652</i> |
| Fax | <i>++44 (0) 1451 861660</i> |

Declares that the product described:

| | |
|---------------|---------------------------------|
| Manufacturer | <i>Auger Torque Europe Ltd.</i> |
| Model | |
| Serial Number | |
| | |

Conforms to the Machinery Directive 2006/42/EC.

It also complies with the essential health and safety requirements, national standards and the transposed harmonised standards appropriate for this product.

Signed by:
(The responsible person)

Dated

REGISTRATION

Complete this form and keep it with the manual



Ylötie 1
FI-33470
Ylöjärvi
Finland
Tel. +358 3 347 8800
Telefax +358 3 348 5511
E-mail: sales@avanttecno.com

MODEL NUMBER:

SERIAL NUMBER:

DATE OF MANUFACTURE:

SUPPLIER / DEALER:

DATE SOLD TO SUPPLIER / DEALER:

DATE SOLD TO ORIGINAL END USER:

OWNER OR OPERATOR:

PARENT MACHINE MAKE & MODEL:

Note; Always quote the serial number in any communication with your supplier / dealer

REGISTRATION

For warranty purposes this form **MUST** be completed and returned to Avant Tecno Oy within 14 days of purchase by the end user.

AVANT[®]
AVANT TECNO OY

Ylötie 1
FI-33470
Ylöjärvi
Finland
Tel. +358 3 347 8800
Telefax +358 3 348 5511
E-mail: sales@avanttecno.com

MODEL NUMBER:

SERIAL NUMBER:

DATE OF MANUFACTURE:

SUPPLIER / DEALER:

DATE SOLD TO SUPPLIER / DEALER:

DATE SOLD TO ORIGINAL END USER:

OWNER OR OPERATOR:

PARENT MACHINE MAKE & MODEL:

Note; Always quote the serial number in any communication with your supplier / dealer

For warranty purposes the form on the reverse of this page should be completed and returned to;

**Avant Tecno Oy
Ylötie 1
FI-33470
Ylöjärvi
Finland**

INTRODUCTION

Avant Tecno Oy thank you for purchasing your new product. This operating manual has been prepared to enable you to operate the equipment in a safe manner.

Avant Tecno Oy Earth Drill Units have been designed for use with specific Avant Tecno Oy mounting frames, Augers, Auger extensions and Auger wear parts. Provided these are used and maintained correctly, they will provide a safe and reliable method of boring holes in the earth.

For information on lubrication and maintenance intervals, see pages 27 to 30
Before operating the Earth Drill, please note:

Your Earth Drill comes complete, filled with the correct amount of oil. There is no need to check the oil level.

Hydraulic hoses must be fitted and tightened to the correct torque (see page 16).

The unit must be run in following the recommended procedure (see page 18).

NOTE:

This operating manual should be used in conjunction with the parent machine's operating instructions.

Instruction books should be regarded as part of the machine. They should always be kept safe with the machine for easy and quick reference.

New or extra copies can be obtained from your Avant Tecno Oy dealer or direct from Avant Tecno Oy.

Avant Tecno Oy Earth Drill Units have been designed for use with specific parent machines along with the Avant Tecno Oy range of mounting frames, Augers, Auger extensions and Auger wear parts. Provided these are used and maintained correctly, they will provide a safe and reliable method of boring holes in the earth.

Avant Tecno Oy continually strives to improve and increase its range of products and therefore reserves the right to alter its specifications at any time without notice or obligation. The company accepts no responsibility for discrepancies which may occur between specifications of its machines and descriptions thereof contained in its publications.

SAFETY NOTES

Protect Yourself

Make sure you wear protective clothing and personal safety items.

You May Need

- A Hard Hat
- Safety Goggles
- Hearing Protection
- Foul Weather Clothing
- Reflective Clothing
- Protective Gloves
- Safety Boots

DO NOT wear items of loose clothing, jewellery or other items and tie up any long hair which could entangle in the controls or other parts of the machine.

Know Your Equipment

Get to know all you how to operate all controls on the machine and the attachments

IF THERE IS SOMETHING IN THE MANUAL WHICH YOU DO NOT UNDERSTAND, CONTACT THE MACHINE AGENT OR MANUFACTURER AND ASK THEM TO EXPLAIN IT TO YOU.

Danger, Warning And Caution

This symbol below has 3 important meanings when used with the following captions.



DANGER: An IMMEDIATELY HAZARDOUS situation that WILL result in DEATH or VERY SERIOUS INJURY



WARNING: A POTENTIALLY HAZARDOUS situation that COULD result in DEATH or VERY SERIOUS INJURY



CAUTION: A POTENTIALLY HAZARDOUS situation that MAY result in MINOR INJURY

Protective And Safety Devices

Keep all protective devices in place and securely fastened. Make sure all guards, shields and safety signs are properly installed and are in good condition.

Check The Equipment

Before you operate the equipment, take time to check your machine and ensure that all systems are in good operational order.

- Never operate the equipment with worn, damaged or missing parts. Use only genuine replacement parts.
- Always ensure that the parent machine is secure and stable with its engine switched off and hydraulic pipes disconnected before carrying out any maintenance work.
- Check for loose, broken, missing or damaged parts. Have everything put into good repair and make sure all safety devices are in place.
- Perform all maintenance procedures outlined for the equipment.
- Always protect hands. Select appropriate gloves when handling the equipment during fitting, removing or adjusting
- Always protect feet with safety boots.



WARNING: Hydraulic fluid under pressure can penetrate the skin or eyes and cause serious PERSONAL INJURY, BLINDNESS OR DEATH.
Fluid leaks under pressure may not be visible. Use a piece of wood or thick cardboard to find leaks. DO NOT USE YOUR BARE HANDS.
Wear safety goggles for eye protection.
If any fluid is injected into the skin, it MUST be surgically removed.
SEE A DOCTOR IMMEDIATELY

Make sure all hydraulic lines are correctly installed

Before applying pressure to the hydraulic system be sure all connections are tight and that lines, pipes and hoses are not damaged. Before disconnecting hydraulic lines, be sure to relieve all pressure.

Hazard Classification (Only applicable to ANSI Safet Labels)



DANGER: IMMEDIATE HAZARD! - Failure to understand or obey this information is likely to result in personal injury or death.



WARNING: Failure to follow these instructions may result in personal injury or death.



CAUTION: Failure to follow these instructions may result in minor personal injury or damage to the machine or the vehicle.



NOTICE: This is important information for the proper use of this equipment. Failure to comply may lead to premature equipment failure.

CLEAN OR REPLACE THE SAFETY LABELS IF THEY CANNOT BE CLEARLY READ OR UNDERSTOOD

Safety Precautions



NEVER operate or assemble the equipment without **fully** understanding the operating instructions of both the equipment unit and the parent machine.

Avant Tecno Oy recommend you receive dealer instruction before operating the unit.

NEVER operate the equipment unless you are in good physical condition and mental health.

NEVER operate the equipment under the influence of any substance (including drugs & alcohol) which might impair vision.

NEVER operate the equipment with worn, damaged or missing parts. Use only genuine replacement parts.

NEVER allow bystanders (including animals) within 6 metres/20 foot of the work area.

NEVER allow minors to operate the equipment.



ALWAYS survey the work area before commencing operations. Check for potential hazards, eg. Electricity or communication cables etc.

ALWAYS ensure that the parent machine is secure and stable with it's engine switched off before carrying out any maintenance work.

ALWAYS ensure the hydraulic oil supply to the attachment is disconnected by uncoupling the hydraulic hose connectors before fitting, removing or adjusting the equipment

ALWAYS wear head protection and eye protection when working on the unit.

ALWAYS protect hands. Select appropriate when handling the equipment during fitting, removing or adjusting the unit.

ALWAYS protect feet. Wear approved safety boots.

ALWAYS follow the parent machine instructions regarding noise protection.

STAY ALERT. Should something break, come loose or fail to operate on your equipment, STOP WORK, lower equipment to the ground, shut off the engine and lock out hydraulic supply, inspect the machine and have repairs or adjustments made before resuming operation.

IDENTIFICATION

Typical Setup

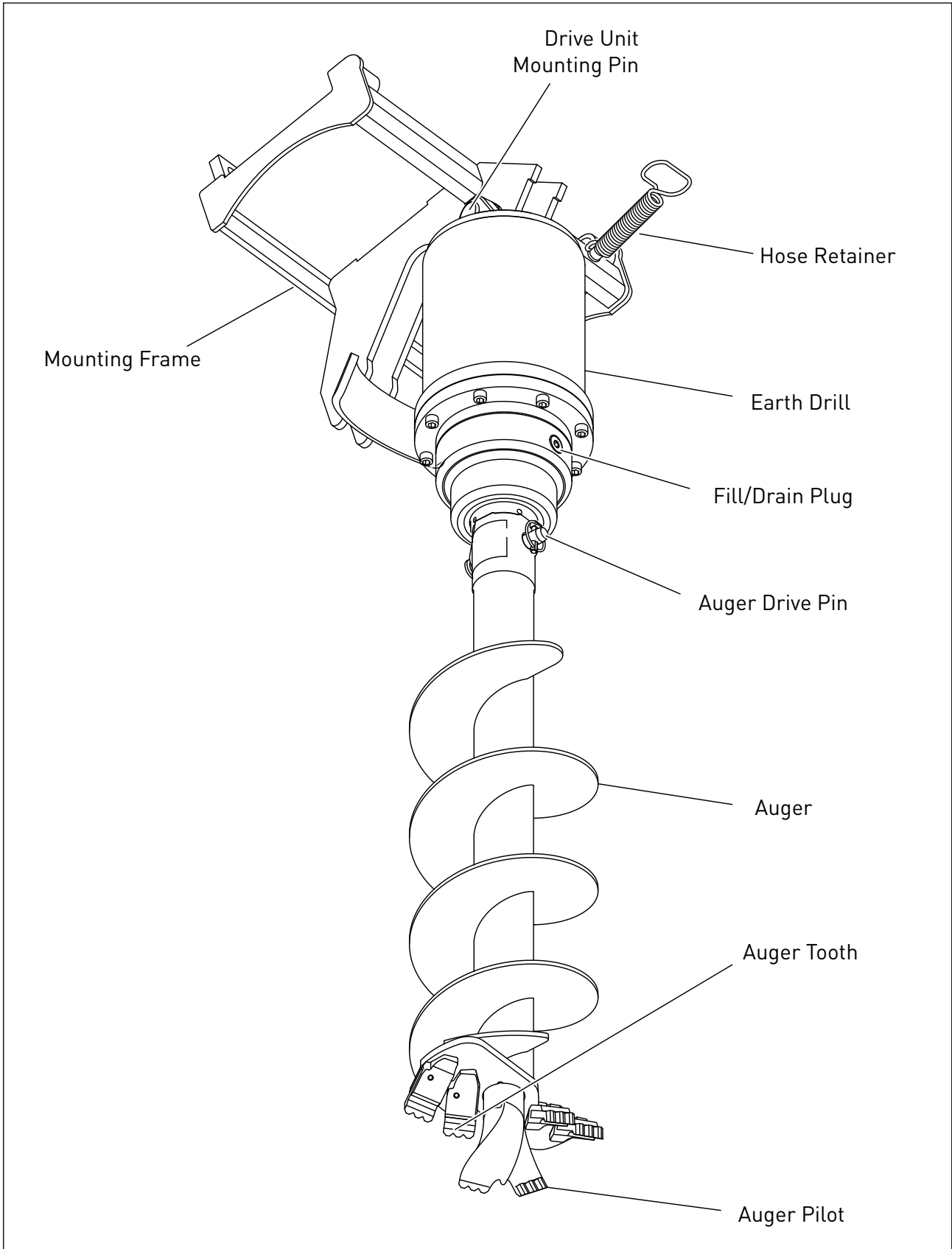

MOUNTING - HITCH FITTING

SAFETY FIRST



ALWAYS work in pairs (2 skilled operatives) whenever Earth Drill unit components are being assembled or disassembled from the parent machine. Always check the weight of the attachment and ensure you have the correct equipment for handling it.



ALWAYS check parent machine:

- Is in correct working order
- Is parked correctly on flat ground
- Has its hand brake **ON**.
- Use suitably rated lifting equipment if required (see data plate for weight).



FITTING: Ensure all components are greased on assembly:

Step 1

Lift the quick attach plate locking pins up and turn them backwards into the slot so that they are locked in the upper position.

If your loader is equipped with a hydraulic attachment locking system, see additional instructions about the use of the locking system from the relevant manuals.

Ensure that the hydraulic hoses are not in the way during installation.

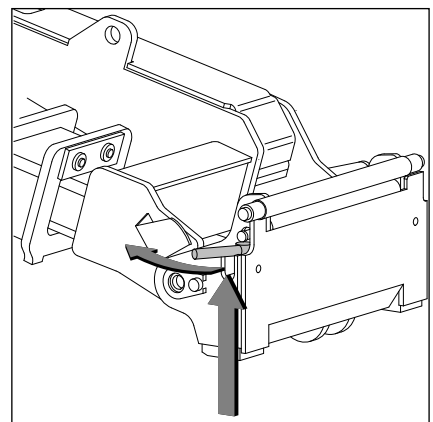

Step 2

Turn the quick attach plate hydraulically to an obliquely forward position.

Drive the loader onto the attachment. If your loader is equipped with a telescopic boom, you can utilise this.

Align the upper pins of the loader's quick coupling plate so that they are under the corresponding brackets of the attachment.

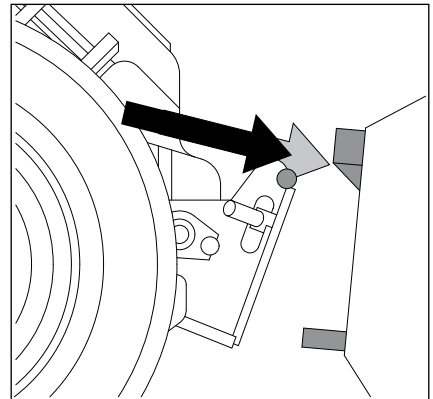

Step 3

Lift the boom slightly – pull the boom control lever backward to raise the attachment off the ground.

Turn the boom control lever left to turn the bottom section of the quick attach plate onto the attachment.

Lock the locking pins manually or lock the hydraulic locking. Always check the locking of pin / pins.

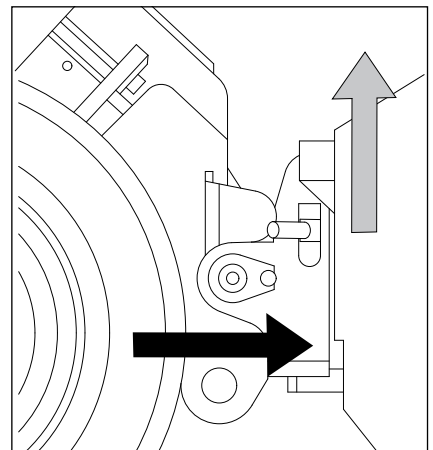



Unlocked attachment may fall on the boom or operator and cause serious injuries. Before moving or lifting the attachment, ensure that the locking pins are in the lower position and come through the fasteners on both sides.



Do not use the automatic return of the locking pins when the attachment or the boom has been lifted at a height of over one metre. Excess tilting increases the risk of toppling over. We recommend that you lower the attachment onto the ground and secure the locking manually

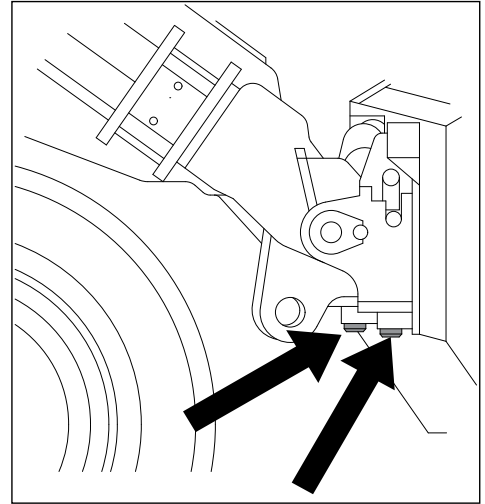

Step 4

Swing the frame to the vertical position.
Working as a pair, lift the Earth Drill in to place with the port opening facing to the left.
Align hood ears with the hole in the linkage block.
Secure the Earth Drill with the Pin (1), Washer (2) and Nylon Insert Nut (3)
Torque to 100Nm/74ft-lb.

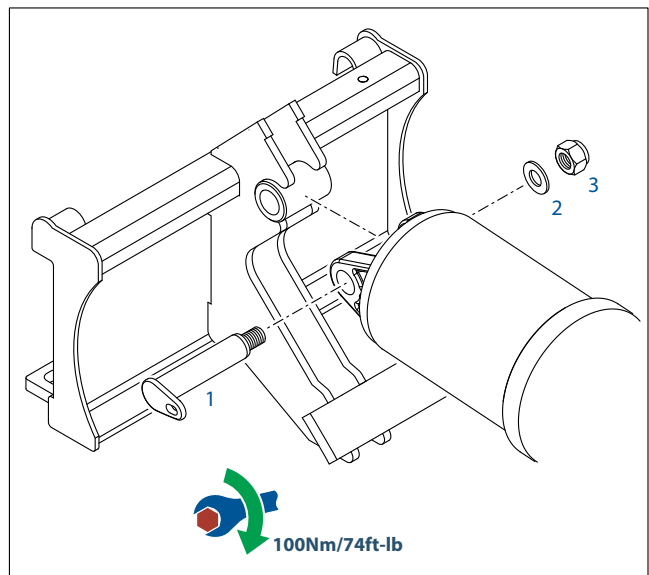

HYDRAULIC CONNECTIONS



WARNING:

Hydraulic fluid under pressure can penetrate the skin or eyes and cause serious personal injury, blindness or death. Fluid leaks under pressure may not be visible. Use a piece of card or wood to find leaks. **DO NOT** use your bare hands. Wear safety goggles to protect your eyes. If any fluid is injected into the skin, it **MUST** be surgically removed. Seek immediate medical attention.



All Avant Tecno Oy Earth Drill Units require a 'flow' and 'return' of hydraulic oil from the parent machine's auxiliary hydraulic power supply to operate. All gearboxes are reversible, but require the host machine to be fitted with a two-way flow auxiliary circuit.

When fitting hydraulic hoses, ensure that they are tightened to the correct torque for the hose fittings (Fig A).

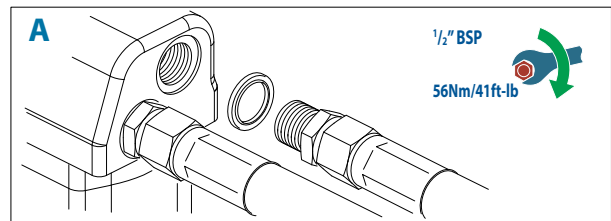

Ensure that the drilling rotation of the Earth Drill Unit is clockwise.

It is critical that the supply of oil is within the stated flow & pressure limits for the particular Earth Drill; Refer to the serial plate on the top of the Earth Drill hood (see page 4).

Connecting the Multiconnector System

Align the pins of the attachment connector with corresponding holes of the loader connector. The multiconnector will not connect if the attachment connector is upside down. Connect and lock the multiconnector by turning the lever towards the loader.

The lever should move easily all the way to its locking position. If the lever does not slide smoothly, check the alignment and position of the connector and clean the connectors. Also shut down the loader and release the residual hydraulic pressure.

To disconnect the multiconnector system, turn off the auxiliary hydraulics of the loader, and unlock the multiconnector. To unlock, push the knob on the side of the connector, and turn the lever to disconnect.

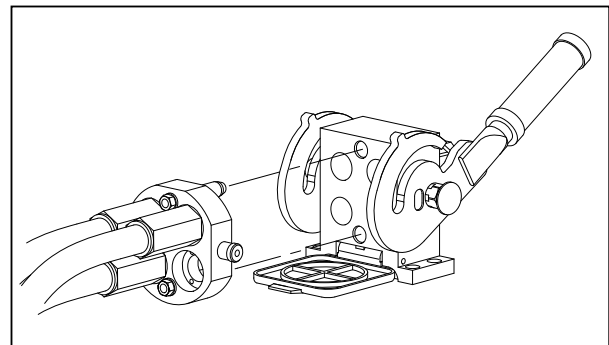

Conventional Quick Couplings (alternative couplings for some loader models)

Before connecting or disconnecting the standard quick couplings, the residual pressure must be released as shown below. The conventional quick couplings will not connect, if there is pressure in the hydraulic system.



To connect and disconnect the standard couplings, move the collar at the end of the female fitting. The hoses should be connected so that the fitting equipped with a coloured cap is connected to the corresponding fitting of the loader. Note that the protective caps on the loader and the attachment can be fastened to each other during operation to reduce the accumulation of dirt. When disconnecting the standard quick couplings a small amount of oil may drip from the couplings.



Wear protective gloves and have some cloth at hand to keep the equipment clean.

Make sure that all three couplings are properly connected, otherwise the hydraulic motor of the mower may get damaged. Before disconnecting conventional quick couplings shut down the loader and move the auxiliary hydraulics control lever of the loader to its extreme positions to release the residual pressure of the hydraulic system.

Releasing Residual Hydraulic Pressure

To make sure that there will not be residual pressure in the hydraulic system of the attachment, shut down the loader engine and move the auxiliary hydraulics control lever of the loader to its extreme positions before disconnecting the couplings. If the fittings will not connect to the loader, the residual pressure must be released. The residual pressure must be released before handling the blades of the attachment and before storage of the attachment.

Hoses Specifications

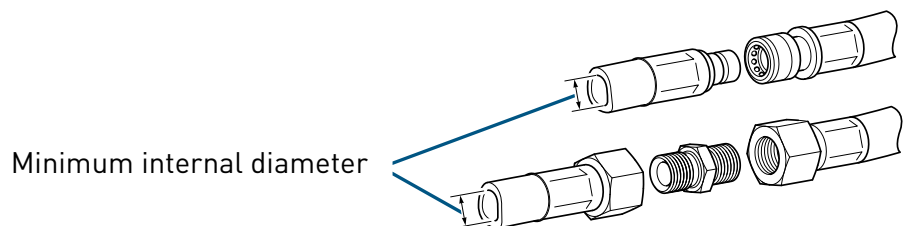

| Minimum hydraulic hose requirements | | |
|-------------------------------------|----------------------------------------|----------------------------------|
| Model | Minimum internal hose diameter (in/mm) | Minimum working pressure Bar/PSI |
| HD35 | 1/2" / 12.7mm | 240Bar / 3480PSI |
| HD45 | 1/2" / 12.7mm | 240Bar / 3480PSI |
| XHD58 | 1/2" / 12.7mm | 240Bar / 3480PSI |
| XHD72 | 1/2" / 12.7mm | 240Bar / 3480PSI |
| XHD92 | 1/2" / 12.7mm | 240Bar / 3480PSI |

Replacement hydraulic hoses **MUST** be rated equal or greater than the minimum working pressure.

RUNNING-IN

To maximise the life of the unit, it must be run in for a period .

To carry out the running in procedure, suspend the Earth Drill in it's vertical, working position.

For the duration of the running in procedure, ensure that no bystanders (including animals) can get within 6 metres/20 foot of the work area.

Operate the motor at 30% of rated pressure for 20 minutes in each direction before application of full operating load.

To further ensure best motor life and maintain warranty, refer to page 27 for lubrication instructions.

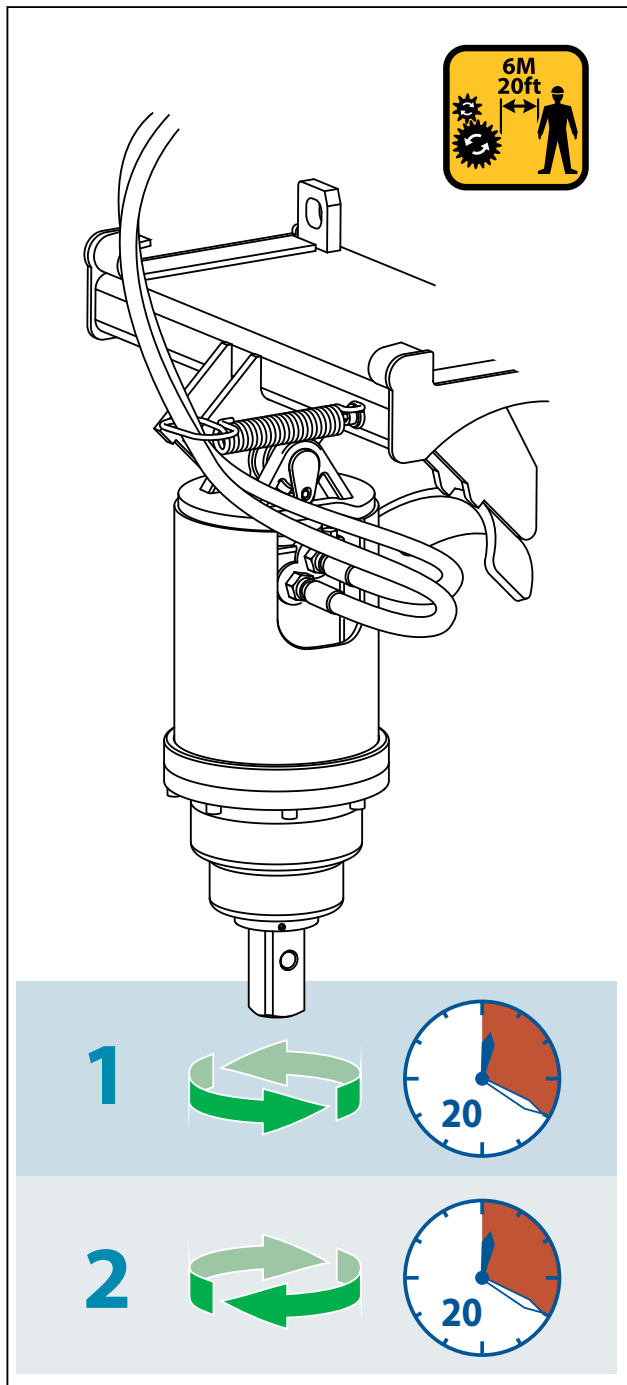

FITTING THE AUGER

SAFETY FIRST



ALWAYS work in pairs (2 skilled operatives) whenever Earth Drill Unit components are being assembled or disassembled from the parent machine.



ALWAYS check parent machine:

- Is in correct working order
- Is parked correctly on flat ground
- Has its hand brake **ON**, its hydraulic circuit locked out and its engine switched **OFF**.

CHECK that the Auger is the correct model and type to fit the Earth Drill Unit.

ENSURE that the Auger connections are clean before fitting.

USE suitably rated lifting equipment if required (see data plate for weight).

Position the Auger in the vertical work position and support it so that it cannot fall over.

Position the Earth Drill over the Auger and align the pin holes.

Lower the Earth Drill Unit onto the Auger

Locate the Auger Drive Pin

Secure the Auger Drive Pin with Linch Pin

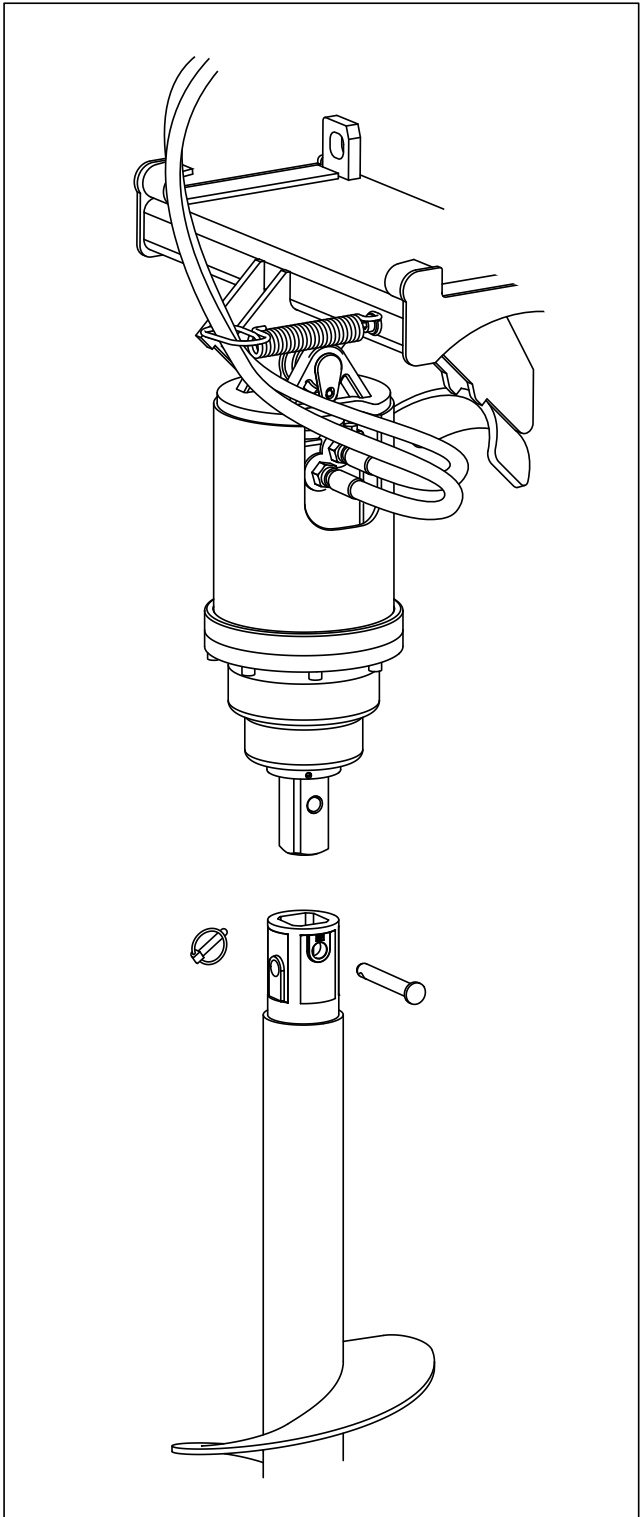

PREPARATION



CONSIDER the topography (e.g. risk of subsidence, slope angle, position to embankments and any previous excavation).



NOTE the type of soil and its condition to enable selection of suitable teeth and pilot

ALWAYS carry out a site survey and risk assessment **BEFORE** starting work



AVOID underground hazards, such as water / gas / electricity / communication lines etc.

If in doubt detection equipment and professional advice should always be considered before carrying out any work.

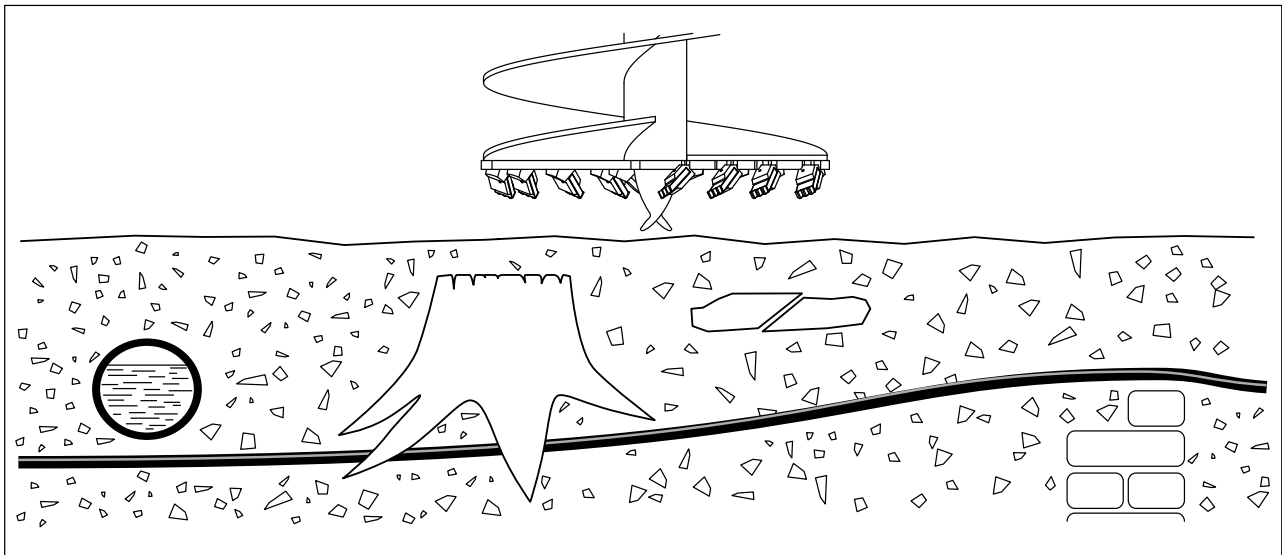

WORKING PROCEDURE

Before commencing work, ensure that ;



The correct hoses are fitted and tightened correctly (See page 16).
The unit has been properly run in (See page 18).



There are no bystanders are within 6 metres / 20 foot of the work area.

SET Auger in a vertical drilling position (Fig A).
ENSURE the direction of rotation is **CLOCKWISE**.
ONLY start drilling after a site survey on a pre-marked safe location (see page 20).
GRADUALLY lower the parent machine arm to apply down force to the Auger.
The harder the ground the more down force required.
Maintain drilling speed. **DO NOT CONTINUALLY STALL** the Earth Drill unit with excessive down force, as this will overheat the hydraulic oil and could damage the machine.

KEEP THE AUGER VERTICAL; (Fig B);

Adjust the angle of the arm, mounting frame and the position of the parent machine as necessary.

MAXIMISE efficiency and avoid damaging the Auger assembly by keeping the Auger vertical.

REGULARLY raise the Auger out of the ground to clear material from the Auger. This will help maintain drilling effectiveness and ensure your machine does not become unstable.

NEVER Drill beyond the length of the Auger.

NEVER leave the Auger assembly suspended.

ALWAYS park with the Auger on the ground.

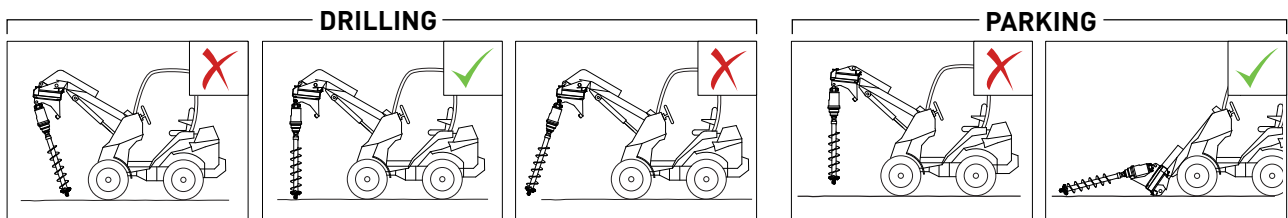
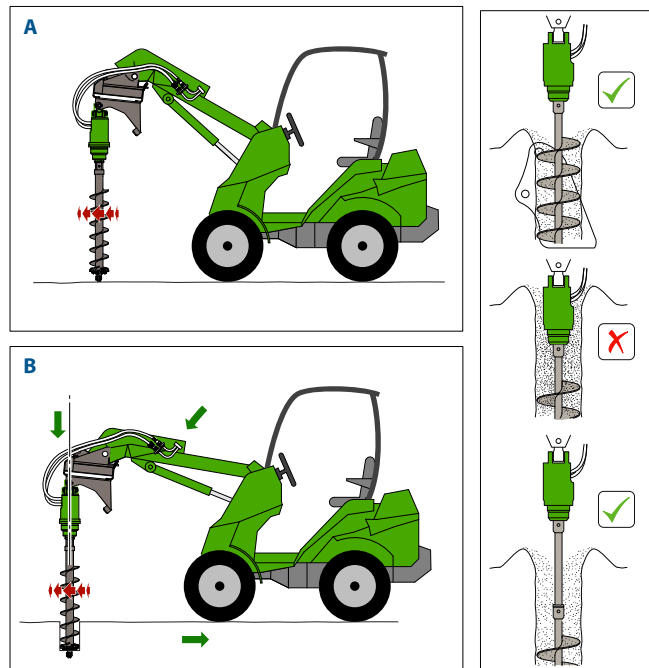

DRILLING WITH FIXED EXTENSIONS

When the required hole depth is greater than the length of the Auger, an Extension should be used. **DO NOT** allow the Earth Drill to enter the hole as seals can be damaged by spoil being extracted.

SAFETY FIRST



Whenever Earth Drill Unit components are being assembled or disassembled from the parent machine **ALWAYS** work in pairs (2 skilled operatives). While fitting components,



ALWAYS check parent machine:

- Is in correct working order
- Is parked correctly on flat ground
- Has its hand brake **ON**, its hydraulic circuit locked out and its engine switched **OFF**.

CHECK that the Extension is the correct model and type to fit the Earth Drill Unit and Auger.

ENSURE that all Earth Drill, Auger and Extension connections are clean before fitting.

USE suitably rated lifting equipment if required.

When using extensions in drilling operations, a length of timber is required for supporting the Auger while removing the Extension. The timber must be of minimum dimensions 150mm (6") deep x 50mm (2") wide and long enough to span the hole being drilled, plus an additional 300mm (12") length at each end.

Fitting A Fixed Extension

When the hole has been drilled to the point where the top of the auger comes within 200mm (8") above ground level;

- Stop drilling.
- Remove the auger from the hole and clear the spoil from the auger.
- Lower the auger back into the hole so that its' weight is supported and remove the Linch Pin and Auger Drive Pin.
- Lift the Earth Drill clear of the Auger and slew it to one side, clear of the hole and set it to a height that will allow the extension to be fitted easily.
- Position the Extension in the vertical work position and support it so that it cannot fall over.
- Position the Earth Drill over the Extension and align the pin holes.
- Lower the Earth Drill Unit onto the Extension.
- Insert the Extension Drive Pin.
- Secure the Extension Drive Pin with Linch Pin.
- Position the Earth Drill and Extension over the Auger and align the pin holes.
- Lower the Earth Drill and Extension onto the Auger.
- Insert the Auger Drive Pin.
- Secure the Auger Drive Pin with Linch Pin.
- Continue drilling.

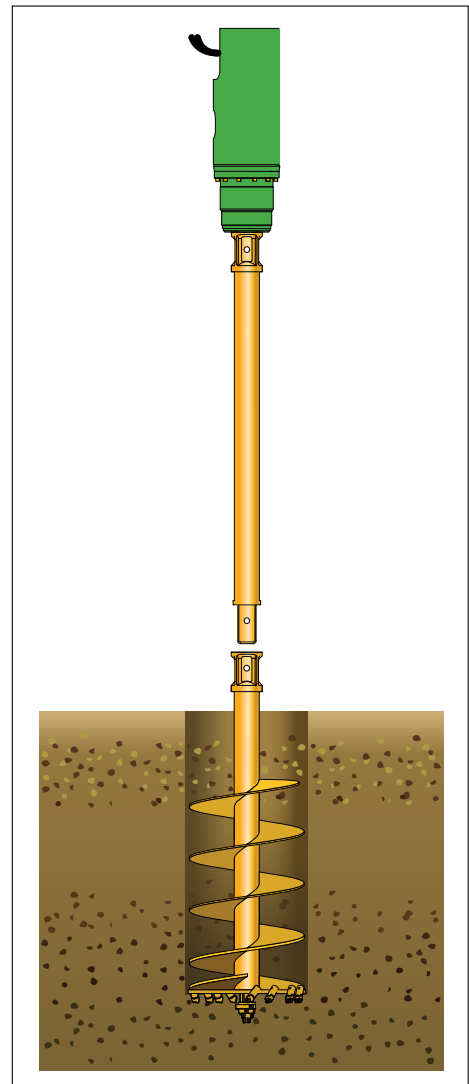

REMOVING A FIXED EXTENSION

If the parent machine has a high reach, it may be possible to lift the auger clear of the hole to clear the spoil without removing the Extension. For smaller machines, and in cases where multiple Extensions are being used, it may be necessary to remove the Extension first.

- Lift the Earth Drill until the Auger Flight is clear of the ground and insert the timber support through the Auger Flight.
- Lower the Earth Drill until the weight of the Auger and Extension are supported by the timber. Make sure that the load is spread equally on either side of the hole.
- Remove the Linch Pin and Auger Drive Pin.
- Lift the Earth Drill until the Extension is clear of the Auger and slew it to one side, clear of the hole and set it to a height that will allow safe removal of the extension.
- Support the weight of the Extension.
- Remove the Linch Pin and Extension Drive Pin.
- Remove the Extension and lay it on the ground.
- Position the Earth Drill over the Auger and align the pin holes.
- Lower the Earth Drill Unit onto the Auger.
- Insert the Auger Drive Pin.
- Secure the Auger Drive Pin with the Linch Pin.
- Lift the Earth Drill to remove the load from the timber support.
- Remove the timber support.

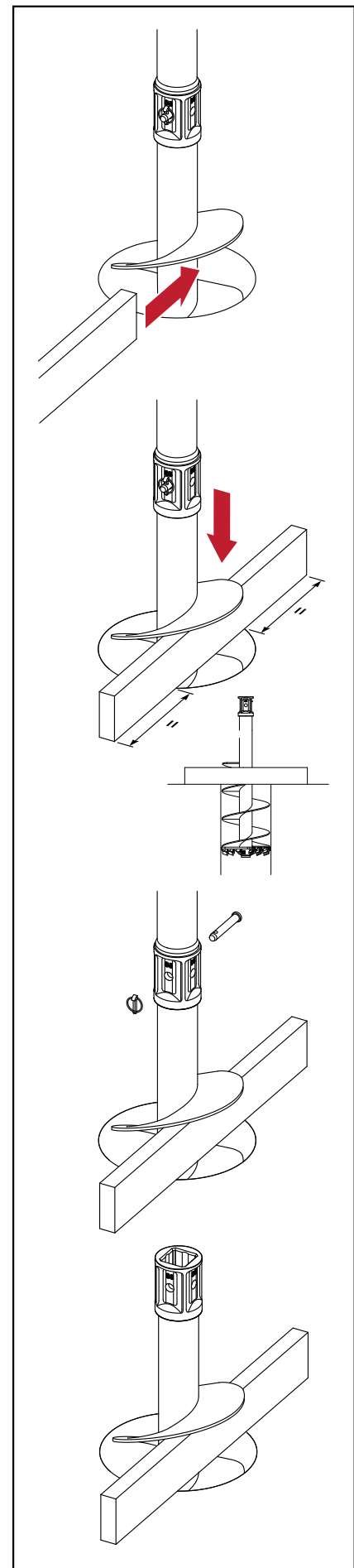

STUMP PLANER

Fitting The Planer

SAFETY FIRST



ALWAYS work in pairs (2 skilled operatives) whenever Earth Drill Unit components are being assembled or disassembled from the parent machine.



ALWAYS check parent machine:

- Is in correct working order
- Is parked correctly on flat ground
- Has its hand brake **ON**, its hydraulic circuit locked out and its engine switched **OFF**.

CHECK that the Planer is the correct model and type to fit the Earth Drill Unit.

ENSURE that the Planer connections are clean before fitting.

USE suitably rated lifting equipment if required (see data plate for weight).

Position the Planer in the vertical work position and support it so that it cannot fall over.

Position the Earth Drill over the Planer and align the pin holes.

Lower the Earth Drill Unit onto the Planer and locate the Drive Pin.

Secure the Drive Pin with Linch Pin.

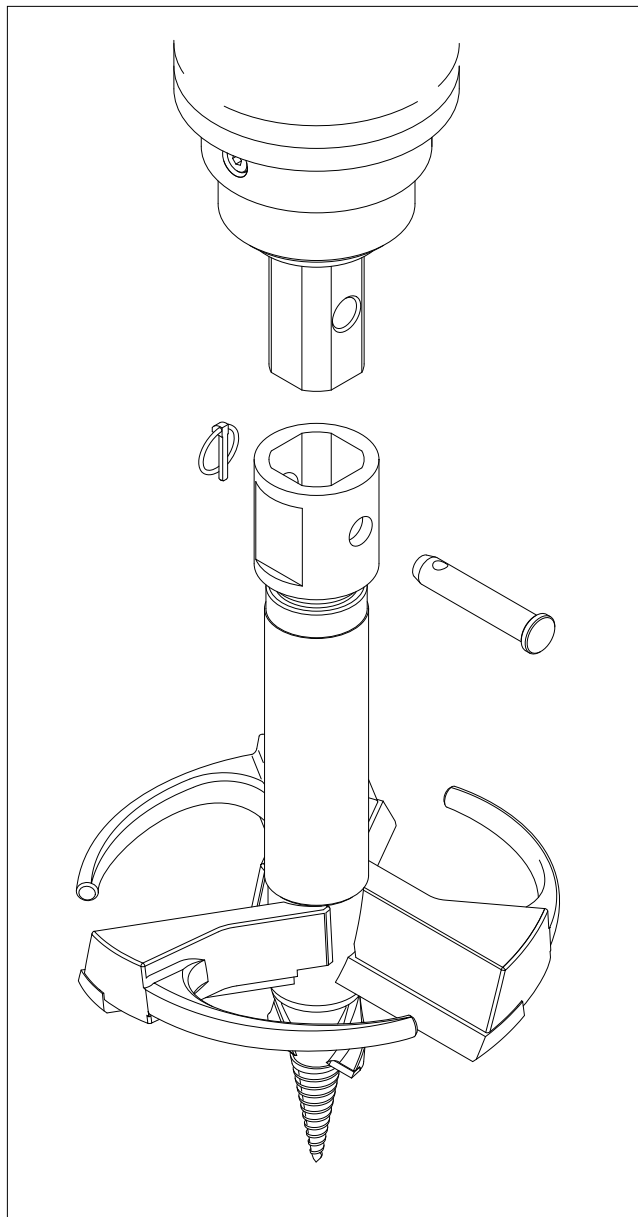

Engaging Blades

The pilot engages with the top surface of the tree stump drawing the tool down allowing the blades to engage with a clean horizontal cut. If the blades fail to engage move the planer forwards and backwards until blades engage then return tool to upright position.

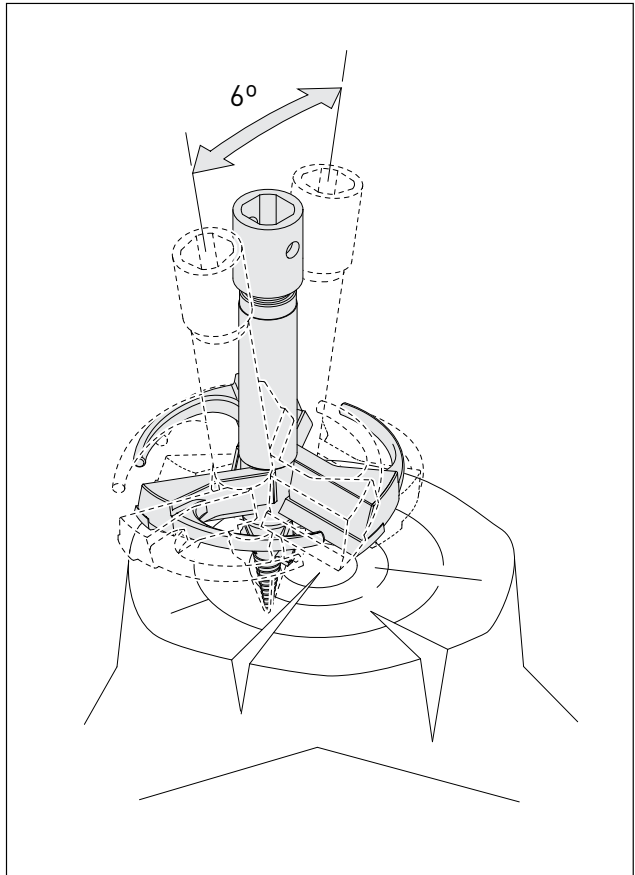

Cutting Sequence

When removing large stumps the planer can be repositioned to overlap each hole in the sequence shown, repeat until the entire stump is removed

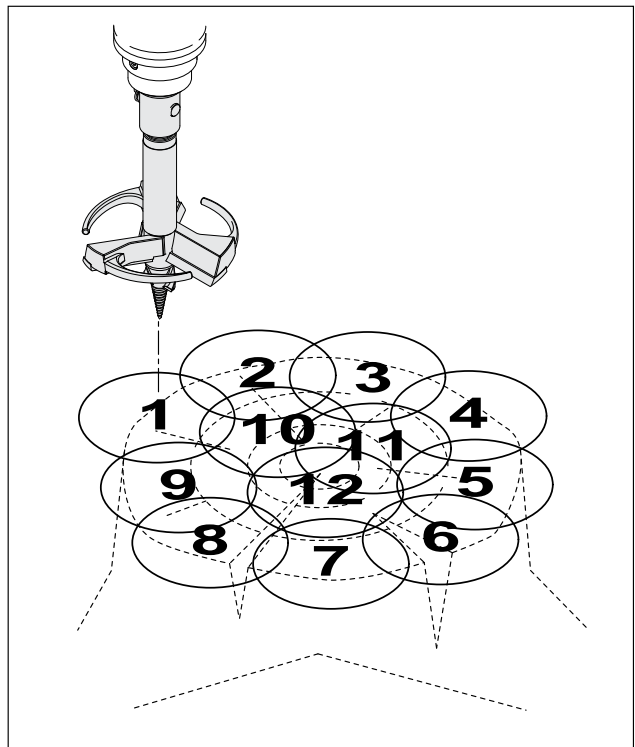

TRANSPORTATION

When attached to the parent machine the standard Auger Unit is free to swing and can be extremely dangerous during transport.

Transportation On Public Highways

ALWAYS remove the Auger and Earth Drill before driving or transporting the parent machine on public highways.

ALWAYS store the Auger and Earth Drill securely and safely when removed from the parent machine taking special care of the hydraulic hoses and connections.

Transportation Within The Job Site

ALWAYS operate the parent machine slowly when on site taking great care to avoid the Auger swinging.

RECOMMENDED: where fitted use the hitch cradle to support the Earth Drill Unit when manoeuvring on site.

Cradle Hitch Support

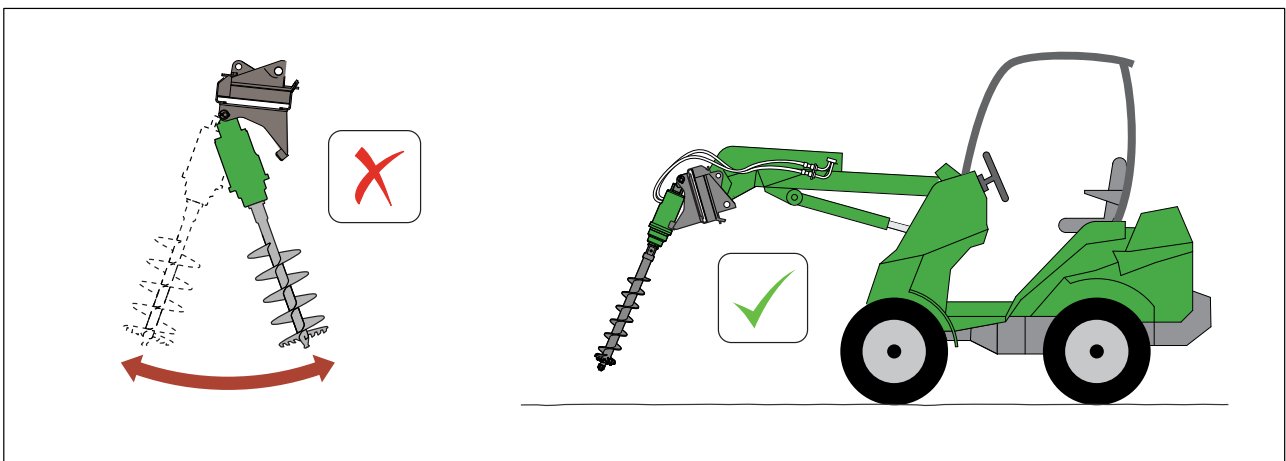

MAINTENANCE & LUBRICATION

SAFETY



Safety at all times



Ensure environmentally safe disposal of waste oil:

Do not pour down drain!



Avoid Fire or Explosion:

Do not smoke near, or expose lubricants to, any possible sources of ignition (e.g. fire, electrical sparks or heat sources.)



All lubricants are toxic and potentially carcinogenic (cancer causing).



Avoid contact with skin and eyes:

Wear suitable protective clothing and gloves.



Always use a suitable barrier cream in case of skin contact.



Always wear eye protection:

In the event of skin contact wash with soap and water.

In the event of eye contact wash with water and seek medical advice.



Do not ingest:

If swallowed seek medical advice immediately.

Service Intervals

Your Avant Tecno Oy Earth Drill Unit features a sealed gear housing filled with gear oil to lubricate the planetary gearset components and bearings within the housing.

Avant Tecno Oy Earth Drill Units are low maintenance, however regular checks for oil leaks and following the service schedules are recommended to ensure a trouble free product.

Weekly:

Earth Drill pivot pin.

Oil Lubrication

Your Earth Drill has been prefilled with Gear Oil. This oil requires regular changing, changing the oil at regular intervals will prolong the life of you unit.

Please refer to the chart on page 29 for recommended oil change intervals.

Important: To maintain product warranty your Avant Tecno Oy Dealer **MUST** record proof of this first oil change.

Please note: the first oil change is free of charge provided that an Authorised Avant Tecno Oy service representative carries it out.

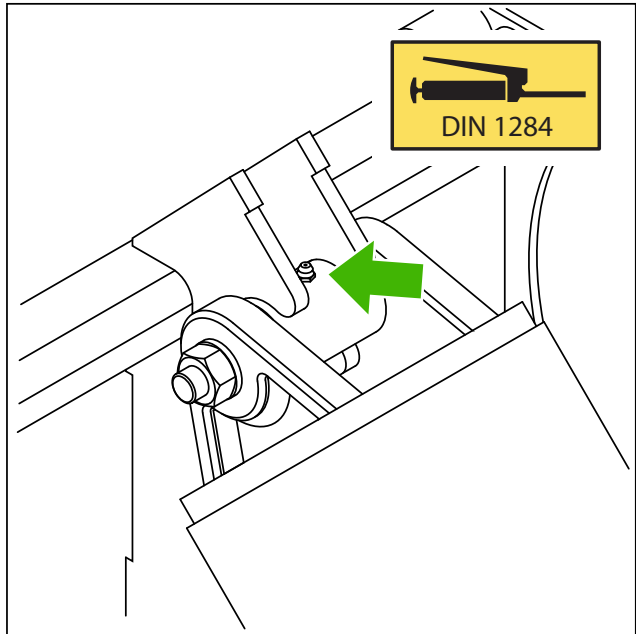

PROOF OF FIRST SERVICE

Dealer Stamp

Dealer Name.....

Date Serviced.....

Recommended Oil Change Intervals

| Oil change frequency | | |
|----------------------|------------------------------------|---------------------------------|
| Model | First oil change after initial use | Subsequent oil change frequency |
| HD35 | 3 Months or 200 hours* | 12 Months or 800 hours* |
| HD45 | 3 Months or 200 hours* | 12 Months or 800 hours* |
| XHD58 | 3 Months or 200 hours* | 12 Months or 800 hours* |
| XHD72 | 3 Months or 200 hours* | 12 Months or 800 hours* |
| XHD92 | 3 Months or 200 hours* | 12 Months or 800 hours* |

* Whichever time period occurs first.

Recommended Lubricants

| Model | Oil Quantity ml/US pints | Grade | Type |
|-------|--------------------------|-----------------|---------|
| HD35 | 400/0.85 | EP 320/AGMA 6EP | Mineral |
| HD45 | 400/0.85 | EP 320/AGMA 6EP | Mineral |
| XHD58 | 850/1.79 | EP 320/AGMA 6EP | Mineral |
| XHD72 | 850/1.79 | EP 320/AGMA 6EP | Mineral |
| XHD92 | 850/1.79 | EP 320/AGMA 6EP | Mineral |

All units are supplied with 320 / AGMA 6EP viscosity oil unless otherwise requested.
 When using or storing the units below -15°C a 150 / AGMA 4EP viscosity oil must be used.
 When using or storing units above 35°C a 460 / AGMA 7EP viscosity oil must be used.

Oil Change Procedure

Before starting any maintenance work on this unit, read the instructions carefully and ensure you have the correct tools, materials and safety equipment to hand.

NOTE: The procedure described below should be carried out by a competent and proficient engineer.

1. Pre-heat the oil by running the unit for 15 minutes (Fig A). Ensure that the unit is safely supported in a horizontal position, with the fill & drain plugs (Fig B, 1 & 2) at top and bottom of the housing
2. Remove drain & fill plugs using suitable tooling and allow oil to drain for a minimum of 10 minutes. For best results leave to drain overnight.
3. Refit drain plug (Fig C, 2) and fill with oil.

Refer to page 29 for correct oil grades and quantities.

4. Refit fill plug (Fig C, 1).
5. Check for signs of leakage, refill as necessary.

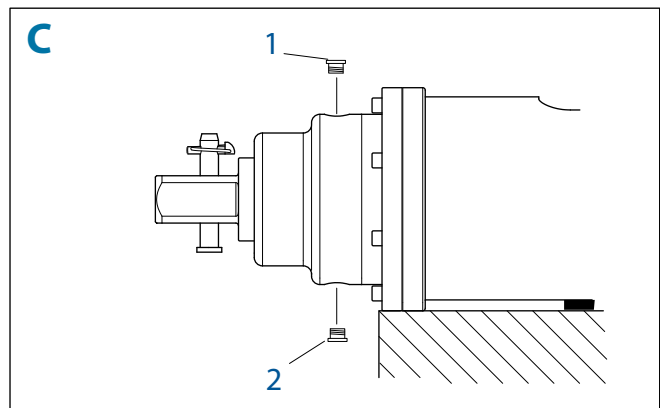
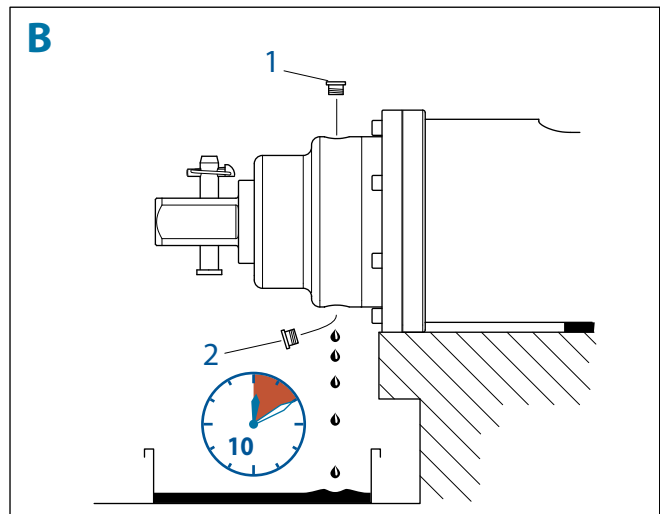
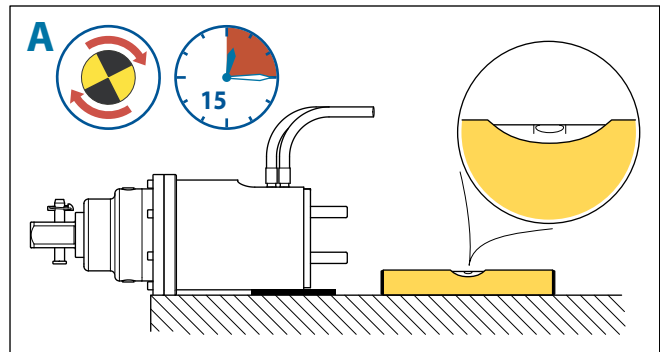

Component Wear

The cutting teeth and pilot should be checked regularly for wear. The diagrams below show acceptable levels of wear.

NOTE; Excessively worn teeth & pilots may cause damage to the Auger

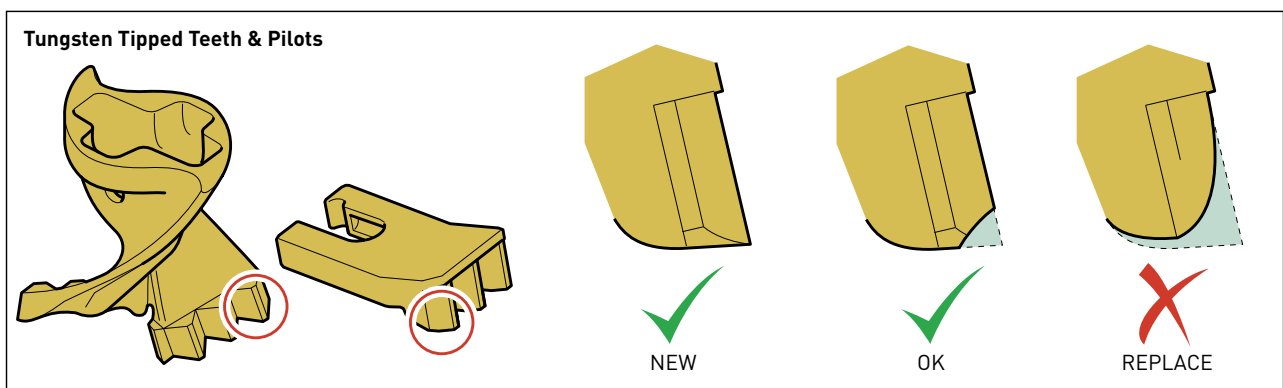
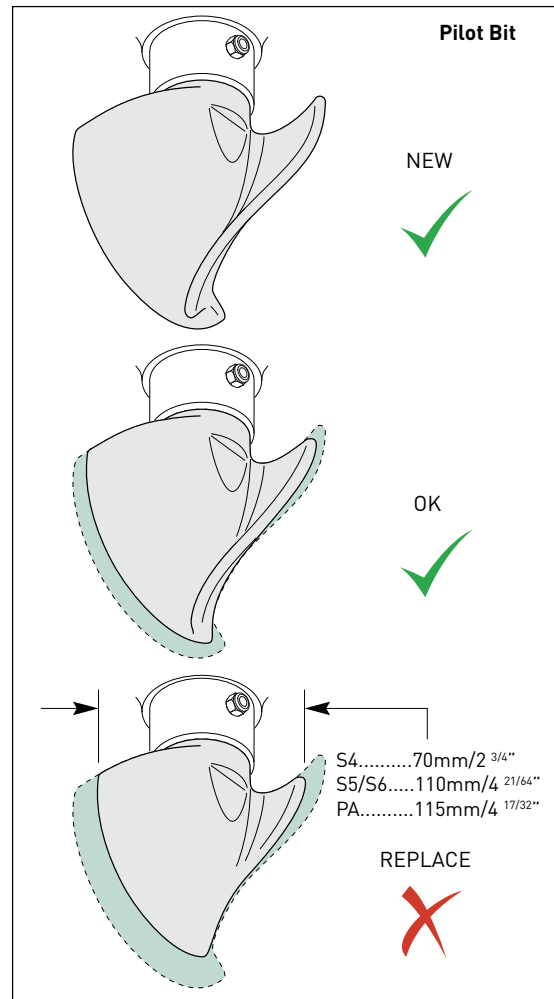
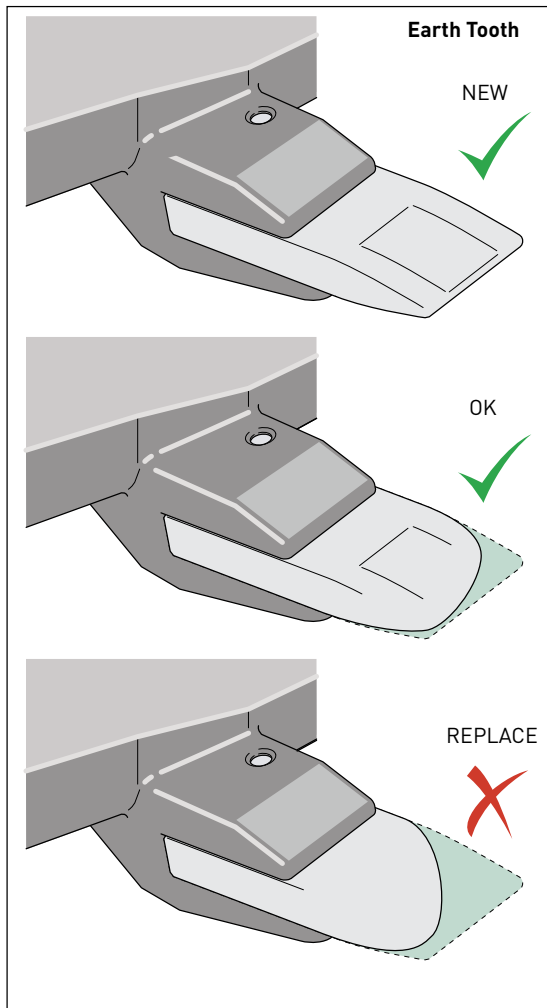

NOTE; Pilots can be replaced by unbolting the old pilot and bolting the new one in it's place. For tooth replacement, refer to page 32.

Auger Tooth Replacement

NOTE; Before removing Auger teeth, ensure that the Auger is horizontal and securely supported with the teeth easily accessible. Always wear appropriate protective clothing.

Shock Lock Teeth

Use a 5mm pin punch to drive the retaining pin out through the bottom of the tooth holder. The tooth and Shock Lock rubber can then be withdrawn.

To install a replacement Shock Lock tooth, fit the rubber into the slot in the tooth.

Press the tooth and rubber into the tooth holder, ensuring that the cut-out for the pin is on the correct side. You may need to use a soft-faced hammer to drive it in fully.

Insert a new retaining pin into the top of the tooth holder, plain end first.

Drive the pin in, ensuring that it locates in the cut-out in the tooth.

Use a pin punch to make sure that the knurled end of the pin is fully engaged in the hole.

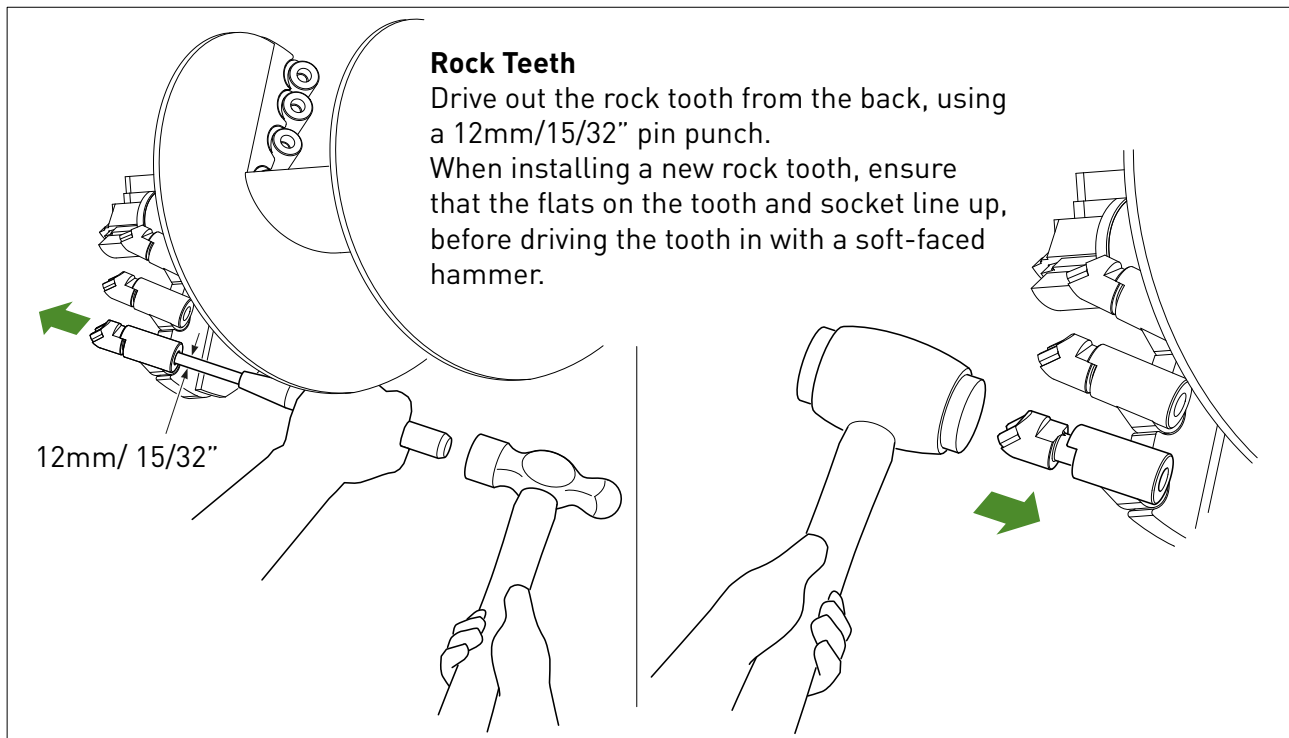
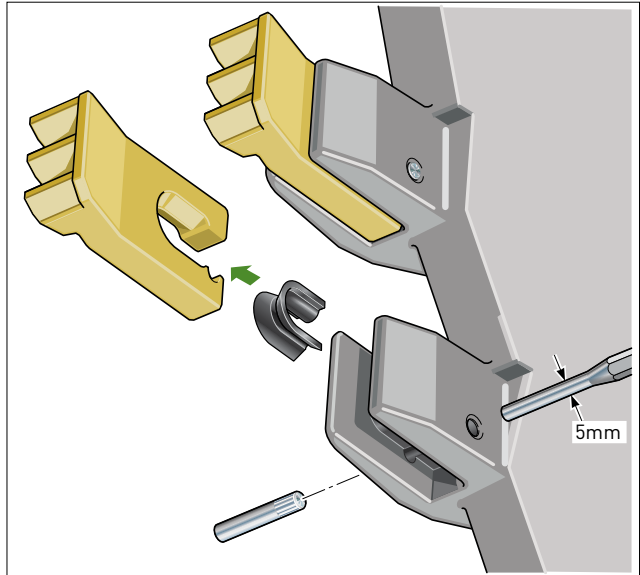

Stump Planer Blade Removal

In the unlikely event that the blades becomes damaged they can be individually removed and sharpened.

This process also applies when the blade loses its cutting edge due to wear.

Remove blades from planer by removing screws from underside of blades.

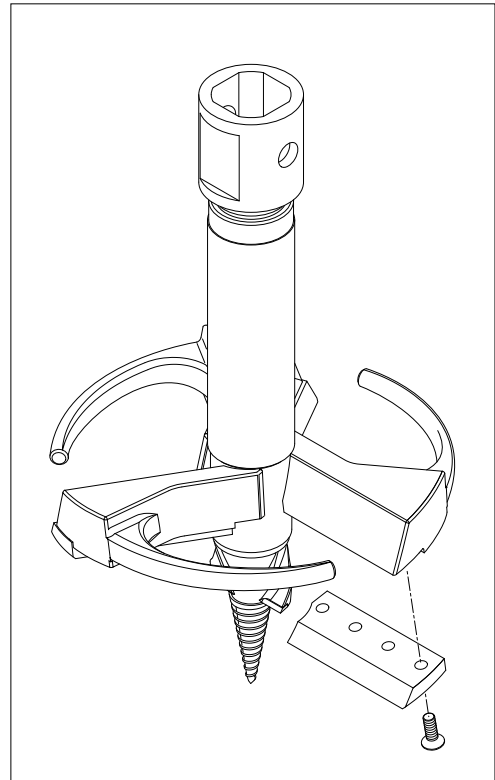

Sharpening Blades

To sharpen the blade first follow the removal process. Using a bench grinder, fitted with a "Green" Silicone Carbide, make several small passes against the cutting face ensuring that the cutting edge angle is maintained at 50 degree.

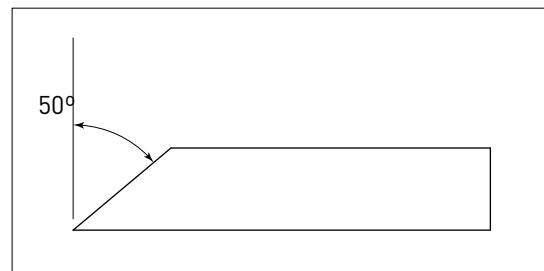

Blade Life

After repeated sharpening the blade will come to the end of its useful life. The diagram details acceptable levels of wear.

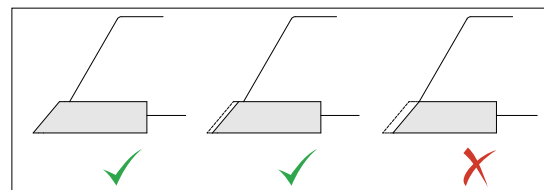

Pilot Replacement

Remove pilot using a 46mm spanner



NOTE; Heat may be required to release thread, use gloves as pilot and spanner may be hot.

To remove the pilot head use a punch to drive the retaining pin out of the pilot. The pilot head can then be withdrawn.

To install new pilot reverse above instructions.

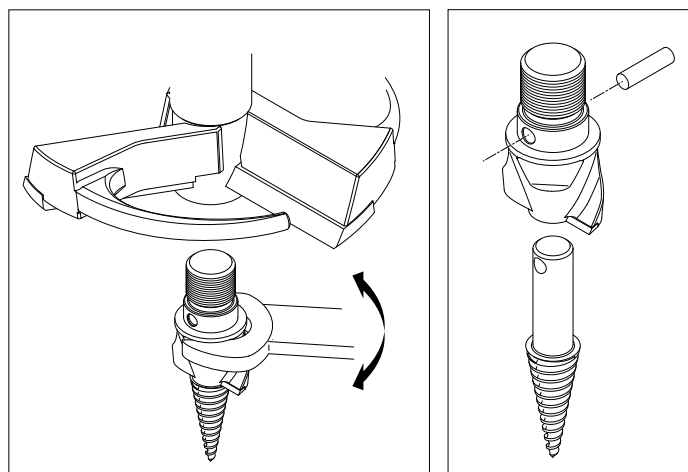

TROUBLESHOOTING

IF IN DOUBT ASK! - Seek Avant Tecno Oy / dealer for advice & repair.

BE SAFE - only use genuine Avant Tecno Oy spare parts.

| MOUNTING FRAME - ASSEMBLY | | |
|-------------------------------------------------------------------------------------------------------------|-----------------------------------------------------------------------------------------------------------------------------------------------------------|------------------------------------------------------------------------------------------------------------------------------------------------------------------------------------------------------------------------------------------------------------------------|
| FAULT Mounting frame does not fit parent machine | POSSIBLE CAUSE Incorrect or non-genuine mounting frame being used Damaged / worn parts | ACTION Refer to both this manual and parent machine's operating assembly instructions Repair or replace with genuine mounting frame |
| MOUNTING FRAME - OPERATION | | |
| FAULT Excessive movement in locating pins | POSSIBLE CAUSE Incorrect or worn locating pins Parent machine pin location / linkage frame pin location worn Damaged parts | ACTION Replace with correct new parts Seek advice from parent machine dealer Seek advice from Avant Tecno Oy /dealer. Only use genuine spare parts |
| AUGER DRIVE UNIT - ASSEMBLY | | |
| FAULT Earth Drill Unit will not fit mounting frame Excessive movement in locating pins | POSSIBLE CAUSE Incorrect / incompatible or non genuine mounting frame / Earth Drill Unit Damaged parts Incorrect or worn pins | ACTION Obtain & fit correct and compatible genuine parts Seek advice from Avant Tecno Oy dealer. Only use genuine spare parts Replace with correct new genuine parts |
| EARTH DRILL UNIT - OPERATION | | |
| FAULT Earth Drill output shaft does not rotate | POSSIBLE CAUSE No oil flow | ACTION Check that quick release coupler(s) are correctly engaged to parent machine Check that parent machine hydraulic system is operating correctly and has sufficient oil of the correct grade (refer to parent machine operating instructions) |

EARTH DRILL UNIT - OPERATION

| FAULT | POSSIBLE CAUSE | ACTION |
|----------------------------------------------------------------|-------------------------------------------------------------------------------------------------------------------------------------------------------------------------------------------------------------------------------------------------------------------------------|-----------------------------------------------------------------------------------------------------------------------------------------------------------------------------------------------------------------------------------------------------------------------------------------------------------------------------------------------------------------------------------------------------------------------------------------------------------------------------------------------------------------------|
| Earth Drill output shaft does not rotate | Parent machine pressure relief valve faulty or set too low Earth Drill unit seized Auger jammed in ground | Test, reset or replace to parent machine's specification Seek advice from Avant Tecno Oy dealer Remove auger from ground before starting machine |
| Slow digging speed / slow rotation of Earth Drill output shaft | Insufficient oil flow from parent machine Incompatible Earth Drill to parent machine combination Incorrect auger, boring teeth or pilot fitted or worn boring teeth/pilot Worn Earth Drill hydraulic motor possibly due to incorrect or dirty oil supply | Check the parent machine hydraulic system is operating correctly and has sufficient oil of the correct grade Check specification. Seek advice from Avant Tecno Oy dealer Ensure auger size is compatible with Earth Drill Unit (not too large) and that boring teeth/pilot are suitable for the ground conditions and not worn Seek advice from Avant Tecno Oy dealer. Only use genuine spare parts. Change parent machine hydraulic oil and filter before fitting replacement drive unit |
| Auger stalls during work | Parent machine pressure relief valve faulty or set too low Restricted oil flow Blocked hydraulic filter Excessive parent machine down force on auger Incompatible Earth Drill / auger size / parent machine combination | Reset/replace pressure release valve to parent machine's specification Check for damaged or incorrect hydraulic hoses and connections Change parent machine filter and oil Reduce down force Check specification. Seek advice from Avant Tecno Oy dealer |

WARRANTY STATEMENT

Avant Tecno Oy grants a warranty of one year (12 months) from the date of purchase for the attachment it manufactures.

The warranty covers repair costs as follows:

- Work costs are covered, if the repair is not performed at the factory.
- The factory replaces any defective components or consumables.

The factory may reimburse the price of components purchased by the customer in special cases that have been agreed in advance.

The warranty does not cover:

- Normal maintenance work or parts and consumables required for it.
- Damages caused by unusual operating conditions or ways of use, negligence, structural changes made without the consent of Avant Tecno Oy, use of non-original parts or lack of maintenance.
- Consequences of a defect, such as interruption of work or other possible additional damages.
- Travel and/or freight costs caused by the repair.

AVANT[®]

YOUR DEALER IS

Avant Tecno Oy

Ylötie 1

FI-33470

Ylöjärvi

Finland

Tel. +358 3 347 8800

Telefax +358 3 348 5511

E-mail: sales@avanttecno.com

www.avanttecno.com

